

C16A

Self restoring rockerpin load cell

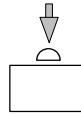

Max. capacities:
20t...100t

Special features

- Self restoring rocker pin
- Simple to install
- Stainless steel, laser-welded
- Complies with OIML R60 regulations up to 5000d for scales class III according to EN 45 501
- NTEP 10 000 divisions class III LM
- Optimized for parallel connection with corner-pre-adjustment
- Meets EMC/ESD requirements according to EN 45 501
- Available options:
 - Explosion proof versions EEx ib IIC T4 EEx d IIC T6
 - Lightning protection

Technical data

Type		C16A	
Accuracy class according OIML R 60		D1 (0,033%)	C3 (0,017%)
Max. numbers of load cell verification intervals (n_{LC})		1000 (10 000 NTEP III L)	
Max. capacity (E_{max})	t	20 30 40 60 100	20 30 40 60 100
Minimum load cell verification interval (V_{min})	% of C_N	0.0200	
Minimum scale verification (e_{min}) to EN 45 501 (Brackets = max. quantity of load cells)	kg		5kg (6c) 10kg (10c) 10kg (6c) 20kg (10c) 10kg (4c) 20kg (10c) 50kg (8c)
Sensitivity (C_N)	mV/V	2	
Sensitivity tolerance ¹⁾	%	$\leq \pm 0.5^1$	
Temperature effect on sensitivity (TK_C) ²⁾	% of $C_N/10K$	$\leq \pm 0.0250^2$	
Temperature effect on zero balance (TK_0)	% of $C_N/10K$	$\leq \pm 0.0285$	$\leq \pm 0.0140$ $\leq \pm 0.0116$ $\leq \pm 0.0234$
Hysteresis error (d_{hy}) ²⁾	% of C_N	$\leq \pm 0.0330$	$\leq \pm 0.0170$
Non-linearity (d_{lin}) ²⁾	% of C_N	$\leq \pm 0.0300^2$	$\leq \pm 0.0180^2$
Creep (d_{DR}) in 30 min	% of C_N	$\leq \pm 0.0330$	$\leq \pm 0.0167$
Input resistance (R_{LC}) (black-blue)	Ω	700 \pm 20	
Output resistance (R_0) ¹⁾ (red-white)	Ω	706 \pm 3.5 ¹⁾	

¹⁾ Smaller tolerances on rated output and output resistance are not necessary. Throughout corner-pre-adjustment the rated output and output resistance are adapted one to the other, so that scale indication is within permissible limits when offcenter load is applied.

²⁾ The data for deviation of non linearity, hysteresis and temperature effect on rated output are typical values. The sum of these data meets the requirements according to OIML R60 respectively NTEP.

Type	Accuracy class according OIML R 60	C16A									
		D1 (0.033%)					C3 (0.017%)				
Max. numbers of load cell verification intervals (n_{LC})		1000 (10 000 NTEP IIII)					3000				
Max. capacity (E_{max})	t	20	30	40	60	100	20	30	40	60	100
Reference excitation voltage (U_{ref})	V	5									
Nominal range of excitation volt. (B_U)	V	0.5...12									
Insulation resistance (R_{is})	GΩ	>5									
Nominal temperature range (B_T)	°C [°F]	-10...+40 [15...105]									
Service temperature range (B_{tu})	°C [°F]	-30...+70 [-20...+160]									
Storage temperature range (B_{tl})	°C [°F]	-50...+85 [-60...+185]									
Safe load limit (E_L)	% of E_{max}	150									
Breaking load (E_d)	% of E_{max}	> 350									
Permissible dynamic load (F_{sref}) (vibration amplitude to DIN 50 100)	% of E_{max}	70									
Max. capacity (E_{max})	t	20	30	40	60	100	20	30	40	60	100
Deflection at max. capacity, approx., ±15% (s_{nom})	mm	0.65	0.75	0.85	1.22	1.57	0.65	0.75	0.85	1.22	1.57
Weight (G), with cable, approx.	kg	2.1	2.3	2.9	3.7	8.0	2.1	2.3	2.9	3.7	8.0
Protection class (IP) to EN 60529 (IEC 529) and DIN 40 050		IP68 (test conditions 100h at 1m water column) IP69K (Washdown cleaning)									
Materials		Measuring body, housing and cable fitting: stainless steel (cable fitting with E_{max} 100t: nickel plated brass); Sealing: Neoprene; connection cable: thermoplast. elastomere									

Wiring code

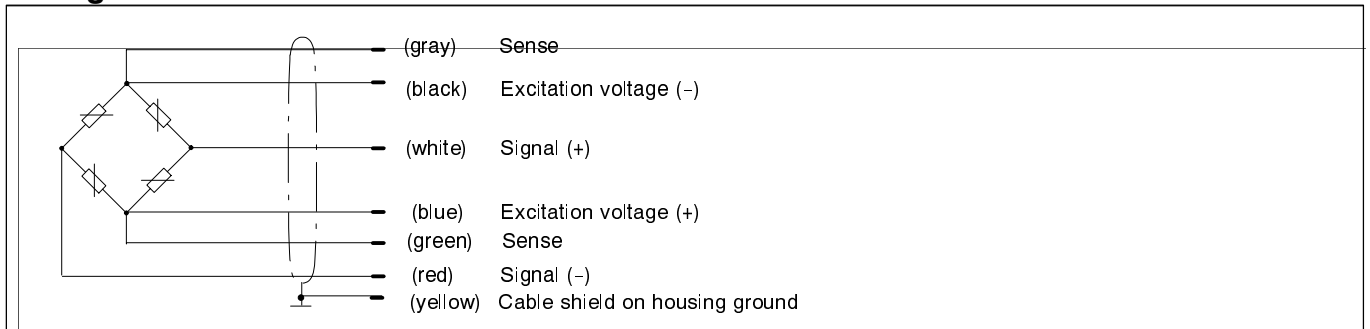

Mounting aids and Dimensions (in mm; 1mm = 0.03739 inches)

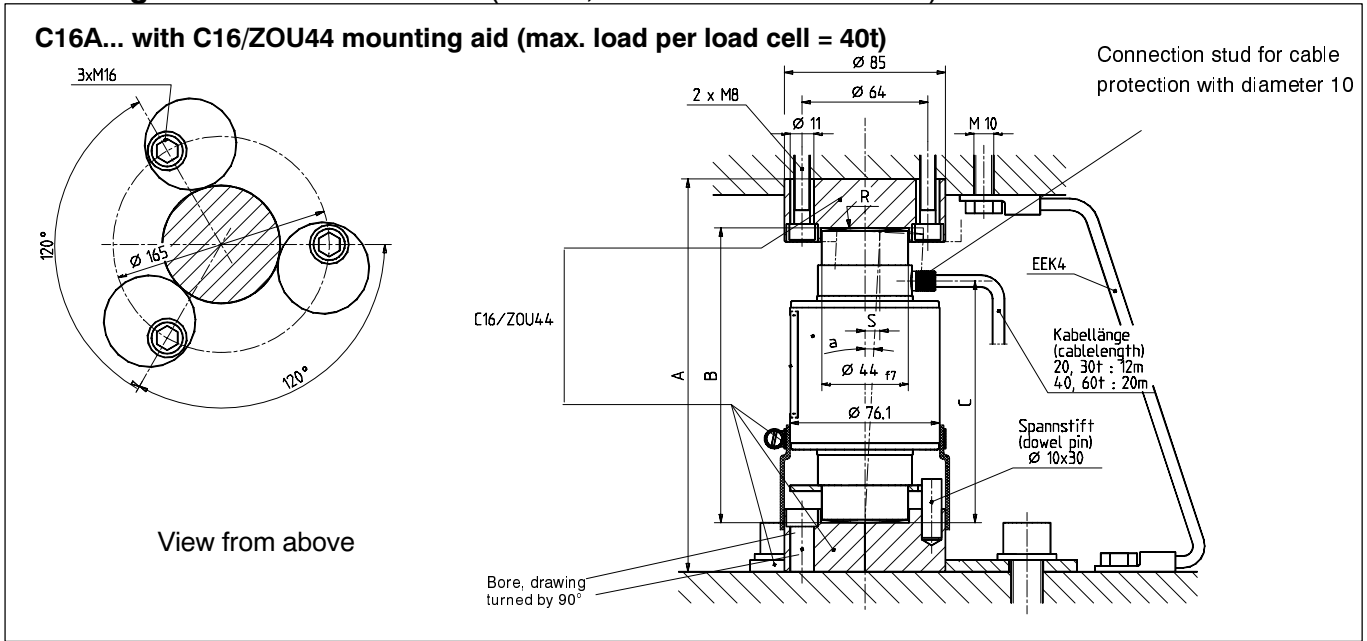

Load cells	Designation of the pendle supports	A	B	C	Ball R	a [max. perm. inclination (in°)]	S _{max}	Restoring force with S _{max} (% of load)	Restoring force with S=1mm (% of load)
C16A.../20t	C16/ZOU44	200	150	66	130	5	13	6.4	0.49
C16A.../30t	C16/ZOU44	200	150	66	160	5	13	9.9	0.76
C16A.../40t	C16/ZOU44	200	150	66	180	5	13	12.2	0.94
C16A.../60t	C16/ZOU44*	260	210	96	220	3	11	5.7	0.52

* Max. load: 40t

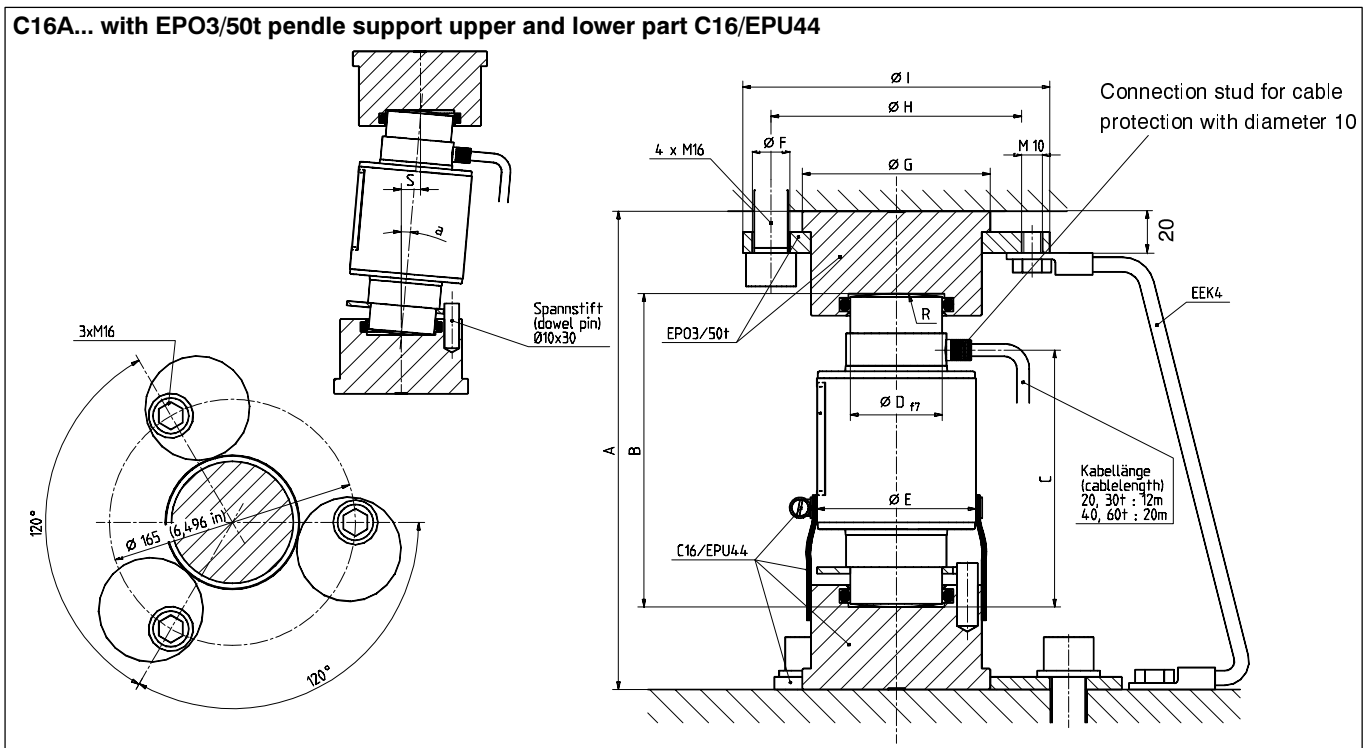

Max. capac. (t)	Pendle support upper	Pendle support lower	A	B	C	ØD	ØE	ØF	ØG	ØH	ØI	Ball R	Max. perm. incl. a [°]	s _{max} *	F _R * with s _{max} (% applied load)	F _R * with s=1mm (% applied load)
20	EPO3 50t	C16/ EPU44	229	150	66	44	76.1	17	89	120	147	130	5	13	6.4	0.49
30			229	150	66	44	76.1	17	89	120	147	160	5	13	9.9	0.76
40			229	150	66	44	76.1	17	89	120	147	180	5	13	12.2	0.94
60			289	210	96	44	76.1	17	89	120	147	220	3	11	5.7	0.52

* s_{max} = max. permissible lateral displacement of load introduction, F_R = Restoring force

Mounting aids and Dimensions (in mm; 1 mm = 0.03739 inches)

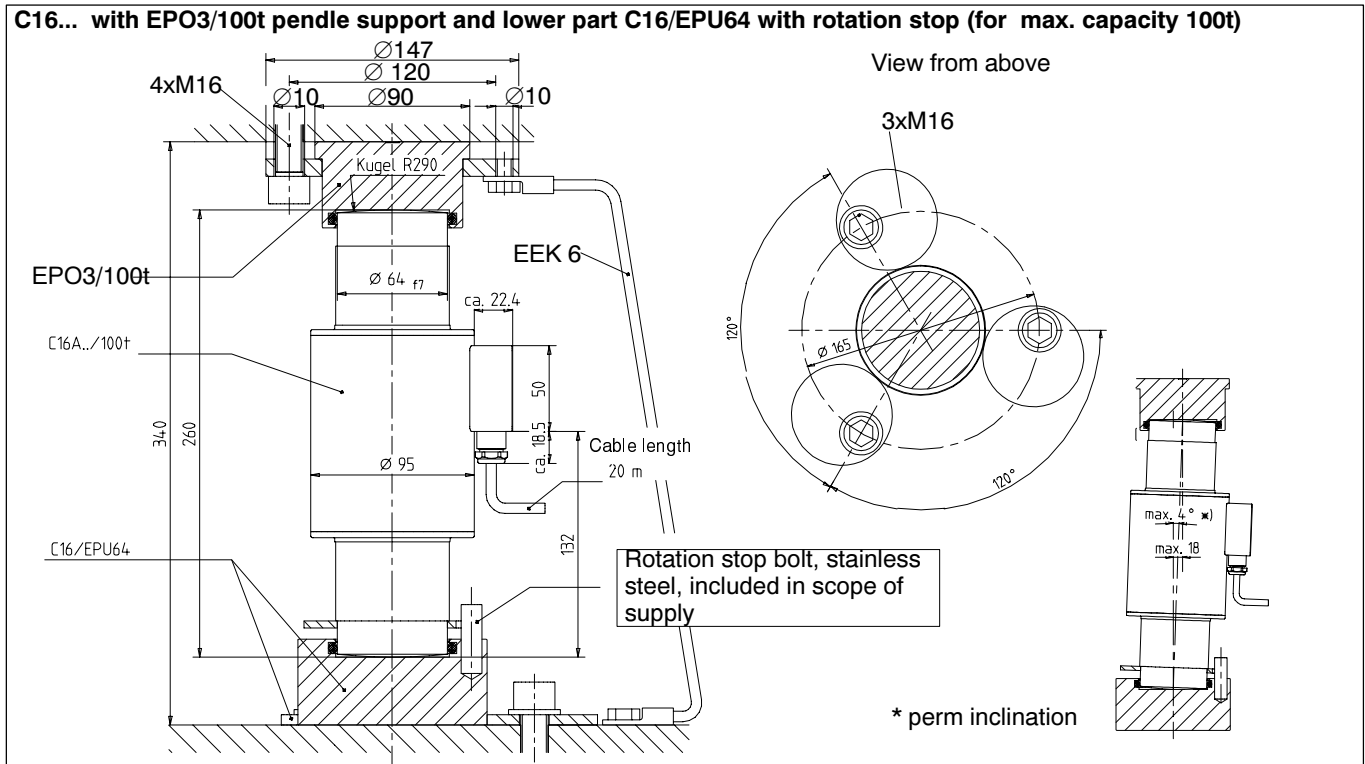

Options

- **Explosion proof version**
-Intrinsically safe circuits in accordance to EEx ib IIC T4
- **Explosion proof version**
-Flameproof enclosure EEx d IIC T6 (see page 38)
- **Lightning protection**
- **Accuracy classes C4 and C5 on request**
- **For max. capacity 200t refer to separate data sheet**

Accessories, to be ordered separately:

- C16/ZOU44 pendle bearing, stainless, for above and below, 3 excentric washers, flexible tube, tube clip - for C16 with load introduction diameter 44mm (for max. load 40t per load cell)
- EPO3/50t pendle support- for max. capacity up to 60t (pendel support, spanner)
- C16/EPU44 lower pendle support, for max. capacities up to 60t (pendle support, 3 excentric washers , flexible tube, tube clip)
- Mounting aid: 2-9290.0057 (3 excentric washers , flexible tube, tube clip)
- Upper pendle support EPO3/100t and lower pendle support C16/EPU64, stainless steel, with 3 excentric washers - for max. capacity 100t



HOTTINGER BALDWIN MESSTECHNIK
HBM Wägetechnik GmbH

Im Tiefen See 45, 64293 Darmstadt
Tel.: +49 (0)1805 / 223 249; Telefax: +49 (0)6151 / 803 586
Internet: <http://www.hbmwt.com>

Modifications reserved. All details describe our products in general form only. They are not to be understood as express warranty and do not constitute any liability whatsoever.

wt.07.99 - 0.1h.bm